

VSR GLOBAL



**No: 5/269A Palraj Nagar,
Thiru Vi Ka Street,
Kandanchavadi,
Chennai-96.**



**E-mail: vsrglobalservice@gmail.com
Phone: +91 9043895321**

VSR GLOBAL



ABOUT US

VSR GLOBAL is one of the premier service and suppliers of valves and related products within the chemical, pharmaceutical, water, food and power generation industries.

Utilizing the very latest technology in specific valve testing equipment, we have the ability to test an extremely wide range of valves and ancillary products to current national and international standards as well as Customers specific requirements.

At Valve Services we are able to accommodate our valued client's special requirements with fast turnaround times, technical expertise and assistance with important and/or difficult projects.

Our staff have many years of combined experience and knowledge specific to valve repair and testing. We assist with all facets of flow control, actuation and instrumentation. We specialize in control valve, pressure reducing valve and relief valves, asset management and valve testing throughout all industries.

VISION

Our vision is to be a quality solution provider in the valve industry for which clients can totally rely upon, incorporating a broad scope of valve repair, testing, sales and valve management throughout India.

MISSION

Our mission is to be the most responsive valve repair and valve supply company, based on quality systems, quality technicians, fitters and testing engineers, quality equipment, wholesale and retail sales and services for all segments of the valve market.

SERVICE VALVES DETAILS

CONTROL VALVE



Size	: 1/2" to 12"
Type	: 2 way, 3 way
Body/ Bonnet	: ASTM A216 Gr. WCB/ ASTM A351 Gr. CF8/ CF8M
Internals	: SS 304/ SS 316 [Hard facing other material on Request]
Gland Packing	: Teflon/ Grafoil

CONTROL VALVE BODY & TRIM SET

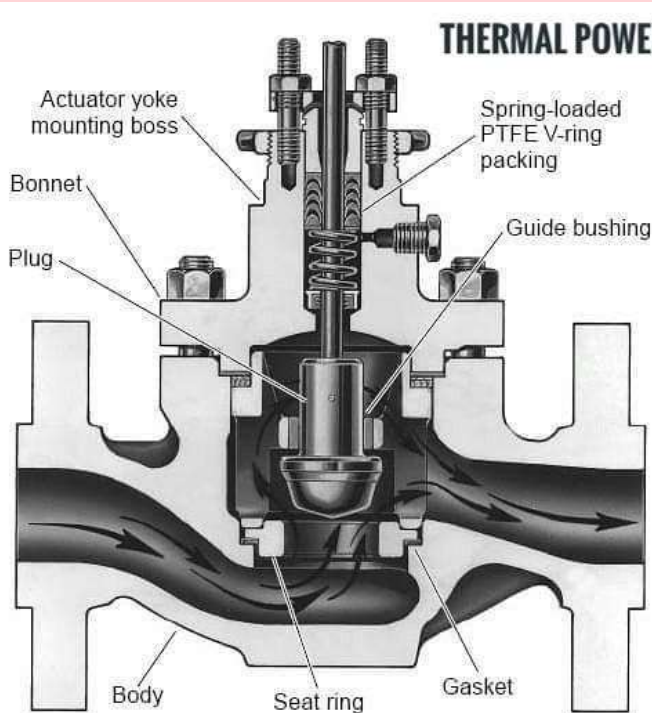

Cross sectional view of a globe valve showing the basic structure

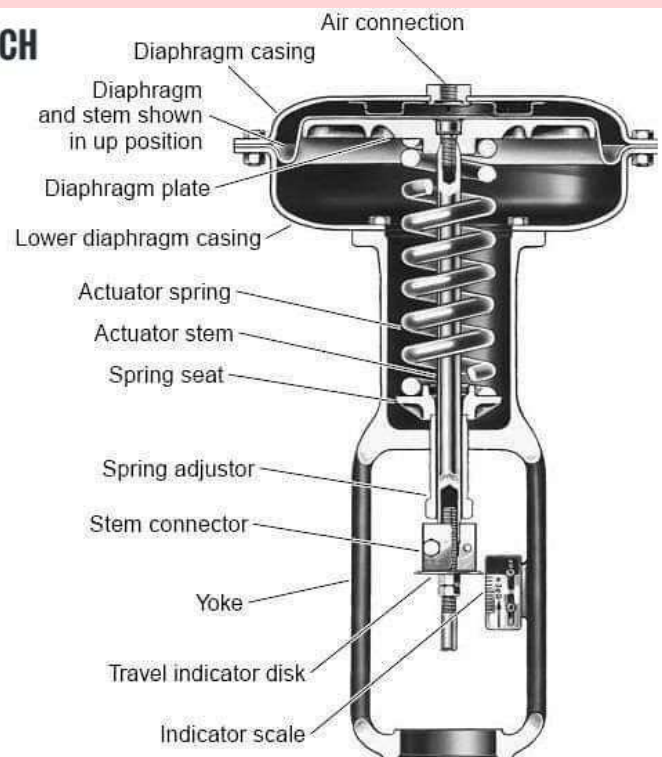

Typical arrangement of a spring and diaphragm type actuator

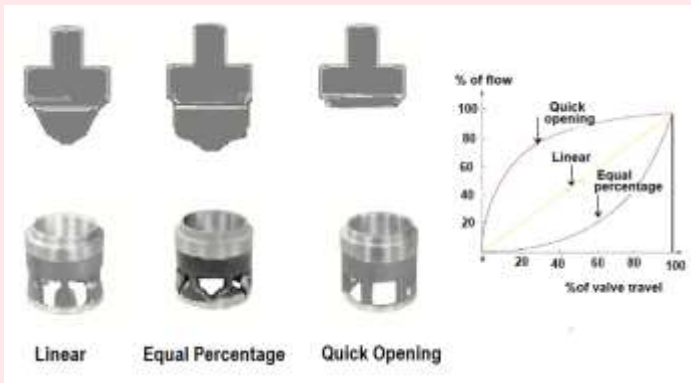

GASKET & GLAND PACKING



Actuator Details

Actuator : Diaphragm & Multi Spring type, Air to open / Air to close as a standard

Pneumatic Pressure : 1.44 to 2.44 Kg/cm²

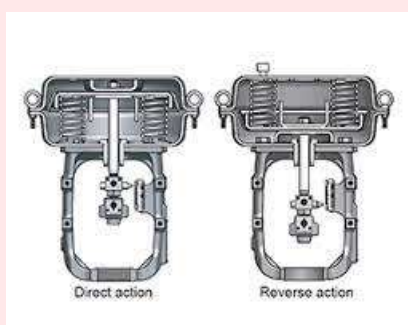

GLOBE VALVE



Size : 1/2" to 8"

Type : 2 way

Body/ Bonnet : ASTM A216 Gr. WCB/ ASTM A351 Gr. CF8/ CF8M

Internals : SS 304/ SS 316 [Hard facing other material on Request]

Gland Packing : Teflon/ Grafoil

GLOBE VALVE TRIMSET



GLAND ROPE



GATE VALVE



- Size** : 1" to 12" Body : CI/ SS 316
- Knife Plate** : SS 304/ SS 316/ SS 310L Yoke : Carbon Steel/ SS 304
- Packing Flange** : SS 304
- Seat** : Resilient/ Metal to Metal Stem Nut : SS 304 Self Locking
- Gland Packing** : Graphite and PTFE ROPE

GATE VALVE SEAT&DISC



GASKET



BALL VALVE



Size	: 1/2" to 12"
Type	: 2 way/ 3 way/ 4 way
Design	: Single Piece/ 2 Piece/ 3 Piece
Seat Packing	: PTFE/ Glass Filled/ Carbon filled
Pressure Range	: ANSI class 300/ ANSI class 800
End Connection	: Screwed Ends ,Socket weld Ends,and Flanged ends class150/300

VALVE SEATING AND TEFLON SEAT

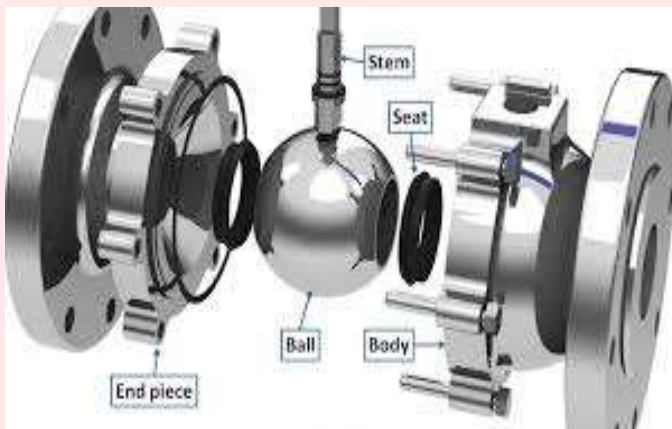

BALL VALVE CARBON SEAT AND SEAL

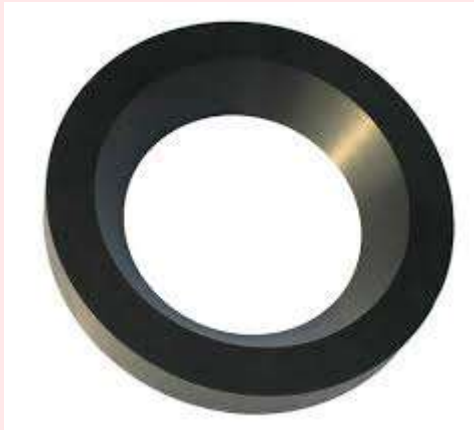

FLASHBOTTOM BALL VALVE



TEFLON SEAT



SPHERICAL DISC BUTTERFLY VALVE



Size	: 2" to 12"
Body	: WCB/ CF8/ CF8M
Pressure Rating	: PN 10/ PN 16
Operating Temp Range	: - 25 to 200°C (depending on MOC)
Seat Leakage	: Tight Shutoff
Operating	: Hand Lever, Pneumatic Actuated

TEFLON SEAT AND CARBON SEAT



BUTTERFLY VALVE



BUTTERFLY VALVE SEAT



Actuator Details

- Type** : Rack and Pinion typ
- Actuation** : Double Acting/ Single Acting
- Mounting Std** : ISO 5211 An International Standard
- Pneumatic Connections** : NAMUR Standard



ELECTRO PNEUMATIC POSITIONER



POSITIONER REPLACE ITEMS



POILET VALVE



PNEUMATIC CYLINDER



SEAL KIT SET



PRESSURE REDUCING VALVE AND PRESSURE RELIEF VALVE (SAFETY VALVE)



Size : 1/2" to 4"
Body : ASTM A351 Gr. CF8/ CF8M/ CF3M
Seat : SS 304/ SS 316

2 WAY ANGLE TYPE CONTROL VALVE



Size : 1/2" to 4" Screwed/ Flanged/Triclover
Body & Bonnet : ASTM A351 Gr. CF8/ CF8M/ CF3M
Stem Packing : Self Adjusting, Spring Loaded Teflon Packing
Trim/ Spindle : SS 304/ 316/ 316L
Seat : Soft Seated Teflon backed by EPDM/ Viton/ EPDM/
Buna Nitrile
Gland Packing : Teflon 'V' Seals, backed by graphite wiper Seal

PTFE PRODUCT DETAILS

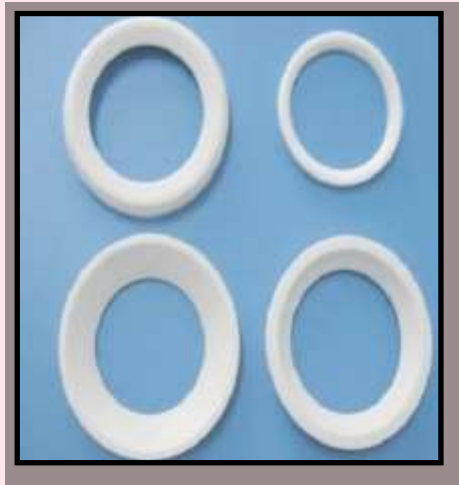

PTFE stands for Poly Tetra Fluoro Ethylene, a synthetic fluoro polymer of tetra fluoro ethylene with an enormous number of applications. Poly Tetra Fluoro Ethylene is the chemical term for the polymer $(C_2F_4)_n$. Teflon™ is a registered trademark and a brand name (Teflon®) owned by Chemours (formally DuPont) and is used on a range of products. Teflon™ is not a specific chemical or product name.

TEFLON DIFFERENT ITEMS:

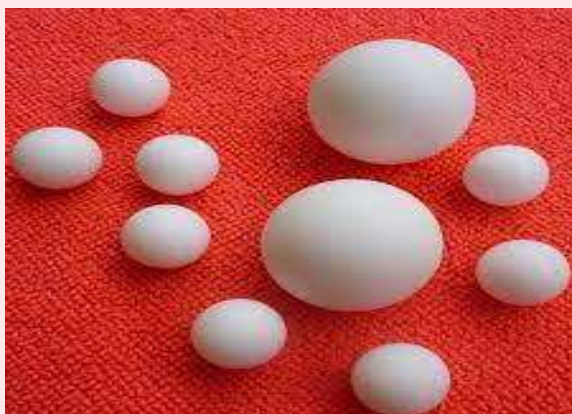

ACCESSORIES



Positioner



Limit Switch



Gear Box



F.R.L



Reversing Solenoid Valve



Quarter-Turn Pneumatic Actuator

